

Unitex exterior profiles are made from a light weight centre with a reinforced coating of pure resins and cementitious minerals.

Quoining

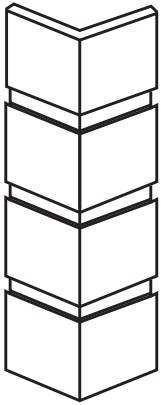

Square-Joint Quoin
300 X 300 x 2700mm
(9 panels high)

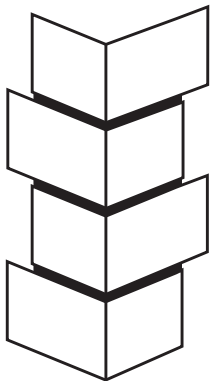

Stepped Quoin
Large panel:
380 x 260 mm
Small panel:
260 x 260 mm
Height: 2600mm
(8 panels high)

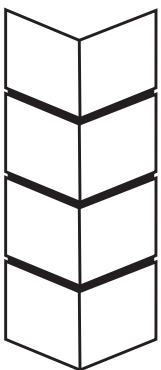

V-Joint Quoin
Sizes:
300 X 300 x 2700mm
350 X 300 x 2700mm
450 X 300 x 2700mm
(All 9 panels high)

Lightweight, factory made and pre-cut guarantees shape exactness to be always the same to allow quick and easy application.

Columns

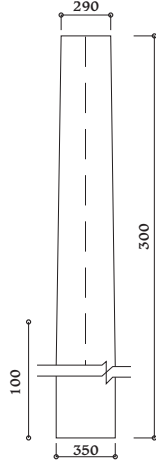

CT260

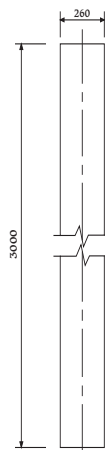
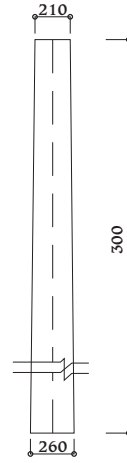

CT260



CF260

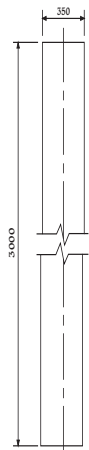

CS350



CF350

Standard products available in large and small versions or arched and curved to any radius required.

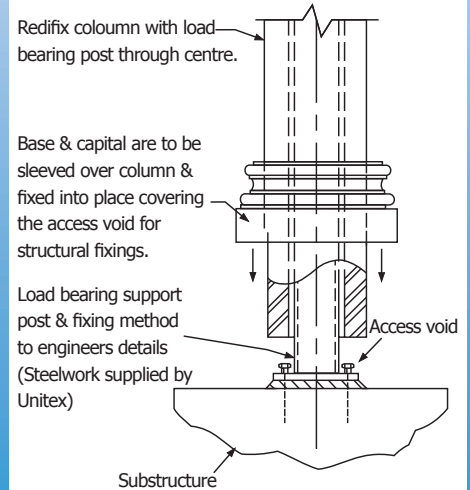

COLUMN INSTALLATION DETAILS
(Top of column similar)

Unitex will supply the steel load bearing support post & mounting brackets to client's specification. Unitex require the engineer's specs for complete pricing of column.

